

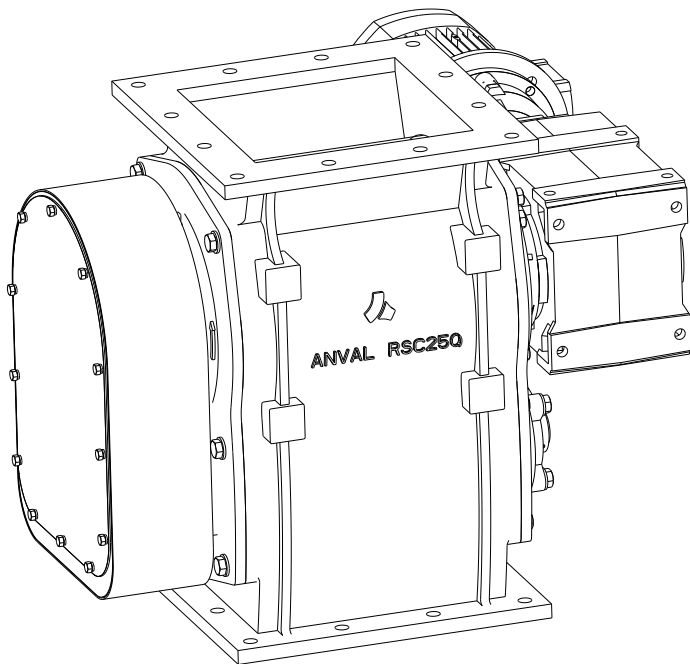

RSCSERIES

RSC Rotary Valve

Dual Rotor (Auto Clean) Rotary Self Cleaning Valve



045
ISO 9001:2015 Reg. No.748699

This manual contains data with respect to our default products only. For any deviation from the default models, kindly refer the deviation sheet in the last page of the manual.

Contents

General Information.....	5
Purpose of the Manual.....	5
Symbols.....	5
Model Identification.....	7
Safety Information.....	8
Safety Precautions.....	8
Conformity to standards	9
Operating Limits & Conditions	9
Safety Instructions	10
Safety Guard.....	10
Special Conditions for Safe Use.....	12
Equipment Identification.....	13
Requesting technical assistance.....	13
Manufacturer’s liability.....	13
Handling & Transport	15
Packaging.....	15
Handling Instructions	16
Moving Packages	16
Moving the equipment	16
Lifting.....	17
Storage.....	17
Installation Pre-requisites & Installation.....	18
Installation Pre-requisites	18
Installation.....	18
Installation Drawing.....	19
Operation and Commissioning	20
Dimension Data – Direct Drive (D).....	21
Table 3: Dimension Details for Inline Drive (E).....	22
Direct Drive (D) Component Information.....	23
Table 5: Direct Drive (D) Component Information.....	23
Anval Standard	24
Purge Sealing	24
Testing & Using the Valve.....	25
Maintenance.....	26
Routine Maintenance.....	27
Lubrication.....	28

Maintenance Schedule	29
Surface Cleaning.....	30
Replacing & Scrapping.....	31
Replacing Parts	31
Scrapping the Equipment	31
Troubleshooting.....	32
Notes.....	33
Notes.....	34

General Information

Purpose of the Manual

This manual has been compiled to provide information on the safety, transport, handling, installation, maintenance, repair, disassembly and dismantling of the RSC 250 valve.

Apart from adhering to established engineering practices, the information given in this manual must be carefully read and applied rigorously.

Failure to adhere to the information provided herein may result in risk to personal health and safety, and economic damages.

This information, provided in the original language (English) of the Manufacturer, may be made available in other languages to meet legal and/or commercial requirements.

Symbols

The operations highlighted by these symbols must be carried out by qualified professionals specially trained in the safety requirements for zones characterized by potentially explosive atmospheres.

Failure to observe these instructions may result in serious risks to personal and environmental safety.

The documentation must be stored by a person with the correct authority and must always be made available for consultation. In case of loss or damage, replacement documentation must be requested directly from the Manufacturer. This manual reflects the engineering standards applied to the valve at the time of commercialization.

The Manufacturer reserves the right to modify, supplement and improve the manual, without the present publication being, for that reason, considered inadequate.

Significant sections of the manual and important specifications are highlighted by symbols whose meanings are given on the following page.



This symbol indicates situations of serious danger which, if ignored, may result in serious risks to the health and safety of personnel.



This symbol indicates the need to adopt specific precautions to avoid risks to the health and safety of personnel and possible economic damages.



This symbol indicates important technical information.

Model Identification

Below table represents codification format for choosing the model:

Opening Size / Model

150	200	250	300	350	400
-----	-----	-----	-----	-----	-----

Rotor Type

N*	M	Q
Closed Scalloped Rotor Cast	Closed Scalloped Rotor Fabricated	Open Scalloped Rotor Fabricated

Optional Sealing

G	A#
Grease Purge	Air Purge

Mandatory for Y & Z temperature

Optional Variation

P	Proximity Sensor
---	------------------

RSC 250 D - - - - - **31 / Deviation**



Please refer to the supplementary manual

Type / Series

RSC
Rotary Self Cleaning Valves

Rotor RPM (Not Required for "B" Selection)

5	6	7	10	12	14*	18	22	31
---	---	---	----	----	-----	----	----	----

* Default with D Selection

Temperature Range

X	Y	Z
200 – 300 °C	300 – 400 °C	>400 °C

Variation / Drive Type

D*	B
Direct Drive	Bare Shaft

*Default Selection

Safety Information

Safety Precautions

Carefully read the instructions given in this manual, especially those regarding safety.

Persons charged with working on the equipment at any time in its service life must be trained specifically for the purpose with special abilities & experience in this area as well as being equipped with the appropriate tools & individual safety equipment. Failure to meet these requirements constitutes a risk to personal health & safety. Use the equipment for the applications envisaged by the manufacturer. Improper use can result in risks to personal health, safety & economic damage.

Keep the equipment at its maximum efficiency by following the routine maintenance schedule. This enables the unit to operate at maximum performance over a long service life in compliance with safety regulations.

When working on the equipment in areas that are difficult to access or hazardous, ensure that adequate safety precautions are taken for the operator & others in compliance with the provisions of law on health & safety at work

All maintenance, inspection & repairs must only be carried out by an expert maintenance technician. It is therefore, essential to implement operating procedures which address potential hazards & their prevention for the entire equipment. The expert maintenance technician must always work with extreme caution in full compliance with applicable safety standards.

During operation wear only the apparel & safety equipment indicated in the user instructions provided by the manufacturer or laid down by applicable laws on safety at work.

Replace worn components with original spare parts. Use the lubricants (Oil & grease) recommended by the manufacturer.

Do not dump polluting materials into the environment. Dispose of all such materials as stipulated by applicable legislation. After replacing lubricants clean the gear unit's surfaces & the walk-on surfaces around the work area.



The applications defined by the manufacturer are those industrial applications for which the equipment has been developed.

Conformity to standards

All RSC250 valves are CE marked and designed in compliance with the provisions of all applicable Essential Health & Safety Requirements, "Machinery directive 2006/42/EC" and, if requested, can be supplied complete with manufacturer's declaration.

Operating Limits & Conditions

Ambient Conditions:

Ambient temperature: Min-0°; Max-60°

Usage of the equipment in the temperature outside the ambient range has to be discussed with the manufacturer.

Do not use the equipment, if not explicitly intended for the purpose, in a potentially explosive atmosphere or where the use of explosion-proof equipment is specified.



If the equipment is to be serviced in a poorly lit area, use additional lamps & ensure that the work is done in compliance with applicable safety legislation.

Noise - Vibration

The equipment operates well below 80db in normal condition with minimal vibration of. Specific noise tests can be conducted at the time of purchase by the manufacturer upon request.

Safety Instructions

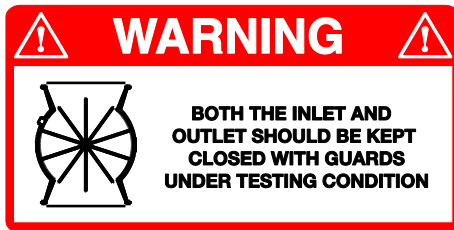
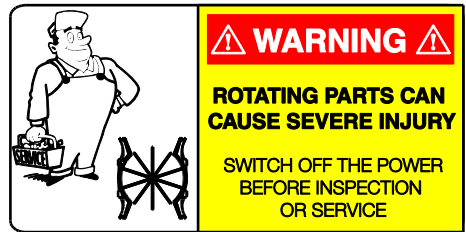

This symbol, indicates the direction in which the rotor must rotate. If the unit is rotating in the wrong direction, possible damage to the unit may result.

Safety Guard

The inlet and outlet of the valves must be guarded in situ to prevent anyone inserting fingers, hands etc., into the rotating valve. This guarding cannot be incorporated into the valve assembly and is not supplied along with the valve. It must be, therefore, be supplied by the installation contractor and fitted as a separate guarding during plant assembly.



Do not install Rotary Airlock valves & feeders in an application which leaves the inlet or outlet flange opening exposed.



Inlet and Outlet flange guards are **MANDATORY** if the inlet or outlet flange opening is exposed while the rotor is running.



Do not insert a finger, stick or any other object. Permanent damage will be caused to the valve and any other object inserted will be amputated.



Rotary Valve

Note: These protective flange covers are available upon request and provided as an accessory to the valve.



Once the protective flange/chain guard cover is removed from valve, do not place hands or feet in the valve or attempt to turn rotor assembly by hand. To test rotation of the rotor, use a soft push bar as shown on the following page.

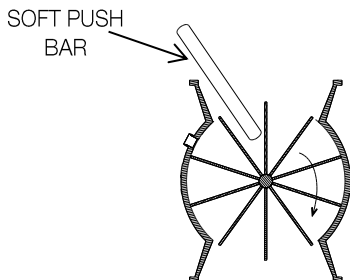

Special Conditions for Safe Use



The following points must be considered while using the valve in potentially explosive atmosphere.

- All relevant metallic parts of the equipment shall be bonded to a fixed and secure platform.
- The equipment shall be installed such that the final installation provides protection from parts of the body coming into contact with the rotating parts of the valve.
- The equipment shall be installed such that the final installation prevents the entry of falling objects into the equipment.
- The equipment shall be cleaned at regular intervals to prevent a build-up of dust on any part of the apparatus.
- Equipment is NOT to be used as an explosion suppression device.
- To prevent hazards arising from propagating brush discharges on the painted parts the equipment shall not be subjected to any charging mechanisms stronger than the manual rubbing of its surfaces

Maximum RPM of the valve should never exceed the criteria given below.

MODEL	MAX. RPM
RSC150	14
RSC200	14
RSC250	14
RSC300	14
RSC350	14
RSC400	14

Equipment Identification

 www.anval.net 	
MODEL :	<input type="text" value="A"/>
S.No. :	<input type="text" value="B"/>
RPM :	<input type="text" value="C"/>
OMFG. DATE :	<input type="text" value="D"/>

A – Model details of the Valve
B – Unique reference code
C – RPM of the Rotor
D – Month &Year of Manufacturing

The nameplate and the information thereon must be readable at all times and consequently cleaned from time to time. Should the nameplate wear and/or become damaged so as to affect its readability or that of even one of the items of information thereon, the user must request a new nameplate from the Manufacturer, and replace the old one.

Requesting technical assistance

For any technical service needs, contact the Manufacturer’s sales network, quoting the information on the unit’s nameplate, the approximate hours of service and the type of defect.

Manufacturer’s liability

The Manufacturer declines all liability for cases of:

- Use of the valve in violation of local laws on safety and accident prevention at work.
- Incorrect installation, disregard or incorrect application of the instructions provided in this manual.
- Incorrect or defective power supply
- Modifications or tampering.
- Work done on the unit by unqualified or unsuitable persons.

The safety of the valve also depends on scrupulous observance of the instructions given in this manual, in particular:

- Always operate the valve within its operating limits.
- Diligently observe the routine maintenance schedule.
- Only authorize trained operators to inspect and service the unit.
- Use only original spare parts
- Do not attempt to use the valve contrary to the instructions supplied.
- The instructions given in this manual do not substitute but summarize the provisions of applicable safety legislation.

Handling & Transport

Packaging

The standard packaging, when supplied & unless otherwise agreed, is not proofed against rainfall. For environments which are under cover & not humid. Storage in all other conditions requires specific packaging.

The most frequent type of packaging is shown below

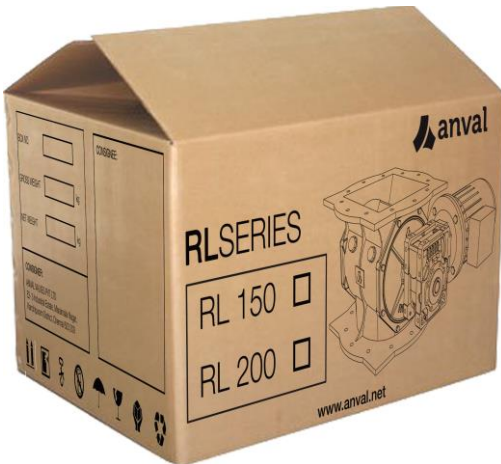

SYMBOL	DESCRIPTION
	This way up
	Do not clamp
	Do not use hooks
	Do not stack
	Keep away from water
	Fragile
	Handle with Care
	Recycle



On the receipt of the equipment, check that the delivery item corresponds to the purchase order & that it is not damaged or faulty in anyway. Refer any nonconformity to the manufacturer at info@anval.net

Dispose of packaging materials as laid down by the provisions of law

Handling Instructions

Handle packages as per the manufacturer's instructions & those marked on the packages themselves. Since the weight & shape of packages may make manual handling unfeasible, special equipment must be used to avoid damage & injury.



The person authorised to handle the product must take all necessary precautions to safeguard their safety & that of all other persons involved.

Moving Packages

Prepare a suitable, delimited area with a level floor or surface for unloading the packages. Prepare the equipment required for handling the package. The lifting & handling equipment used (e.g. crane or lift truck) must have adequate capacity for the weight & size of the load, taking into account its attachment points & centre of gravity. If required, this information is indicated on the package itself. Bind heavy packages with chains, belts & steel ropes after checking whether they are capable of sustaining the weight of the load, which is generally specified.

Moving the equipment



All the following operations must be done with due care & caution without sudden movements

- Identify the attachment points for lifting the equipment.
- Prepare the gear unit for lifting by attaching straps, hooks, shackles etc., to its attachment points, or alternatively, use a pallet for moving the load. If using a crane, first lift it out of its packaging.
- If using a lift truck or pallet truck, remove the packaging & fit the truck's forks at the indicated positions
- First lift the load very slowly to check that it is stable.
- Move the equipment to the unloading area & lower it gently into position, taking care not to cause sudden oscillations while moving it.



Use the eye bolts in such a way that it manages the entire load in conjunction with centre of gravity.

Lifting



When lifting, use accessories such as eyebolts, snap hooks, screw clamps, straps, ropes, hoax etc. which are certified & adequate for the load.

The load must not be allowed to sway or oscillate by more than 15degree in any direction when being lifted. If the oscillation exceeds the limit, stop & repeat the lifting operation as instructed.

Storage

- Do not store the unit in excessively humid conditions or where it is exposed to the weather (do not store outdoors)
- Do not place the equipment directly on the ground
- Place the equipment on a stable base & make sure that it is not subjected to accidental displacements
- Store the packaged equipment in accordance with the instructions on the packaging itself
- If the equipment is stored for more than 6 months, fill the gear unit with lubricating oil & cover all machined external surfaces with a quality rust proofing product)
- Safety precautions to be taken when returning the equipment to service after storage:
- The external surfaces must be thoroughly cleaned of all rust proofing products, contaminants & other impurities (use a standard commercial solvent). Do this outside any explosion hazard area.
- The solvent must not touch the seal rings as this can damage them & render them ineffective.
- If the oil or protective material used during storage is not compatible with the synthetic oil used during the machine's operation, the interior of the unit must be thoroughly cleaned before filling with the operating oil.

Installation Pre-requisites & Installation



The entire installation process must be planned based on the general design of the machine. The person authorised to do the work must, if necessary, implement a safety plan to safeguard all persons directly involved & rigorously apply all applicable legislation.

Installation Pre-requisites

- Thoroughly clean all packaging materials & protective product residue from the equipment if any.
- Check that the data on the nameplate corresponds to that which is specified on the order.
- Ensure that the structure to which the equipment is to be mounted is sufficiently robust & rigid to support its weight & operating stresses.
- Check that the machine on which the equipment is to be mounted is switched off & cannot be accidentally switched on.
- If the work environment is corrosive for the equipment, take the special precautions required for aggressive environments. In this case, contact us for sales service.

Installation

- Place the equipment in the vicinity of the installation area.
- Mount the equipment & secure it to the structure at the points provided. The equipment should be secured to the structure through all the mounting points on the mount specified (flange)
- **Preferred position:** It is best to install in a vertical position. An angle of up to 20degree can be used, providing shaft is in horizontal position & angle is in anti-clockwise direction (when viewed from drive end)
- **Bolting:** Ensure all bolting is right & valve is mounted securely to installation.
- **Housekeeping:** Ensure entry to valve is clean & no foreign objects are in the system that can feed into the valve.
- **Rotation Direction:** Rotor must rotate in a clockwise direction when viewed from the drive end.

Installation Drawing

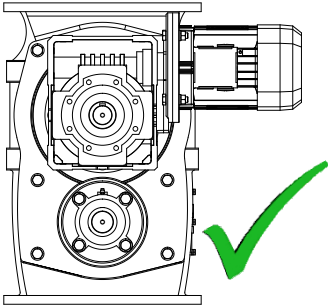
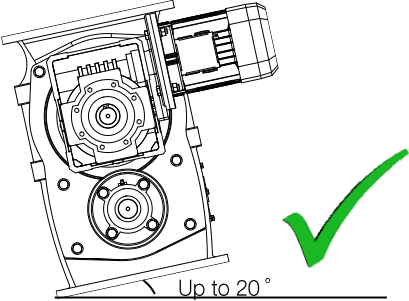
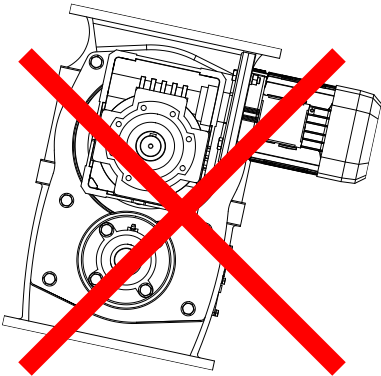
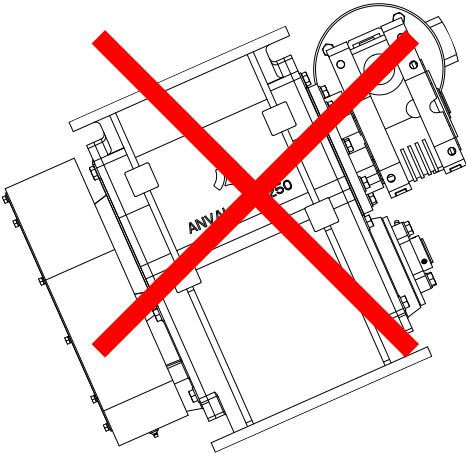
<p>HORIZONTAL Preferred Mounting Positions</p>	<p>TILTED ANTI CLOCKWISE FROM DRIVE END Acceptable</p>
	
<p>TILTED CLOCKWISE FROM DRIVE END Not recommended</p>	<p>SIDE TILTED WITH SHAFT ANGLED Not recommended</p>
	

Operation and Commissioning

- Speed has been set at the factory end based on the customer's requirement
- In case of Chain drive (C) small variations in speed can be achieved by changing the sprocket.
- Valve's performance depends on the performance of the system where it is installed, thus any major deviation from the defined specification will call for complete investigation.
- Within the warranty period any dismantling of valves has to be carried out under the vigilance or guidance of the company's officials.

Rotary Self Cleaning Valve Dimension Data – Direct Drive (D)

TOP VIEW

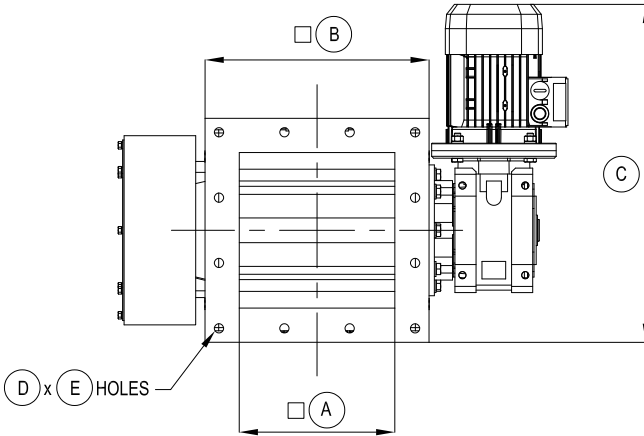

FRONT VIEW

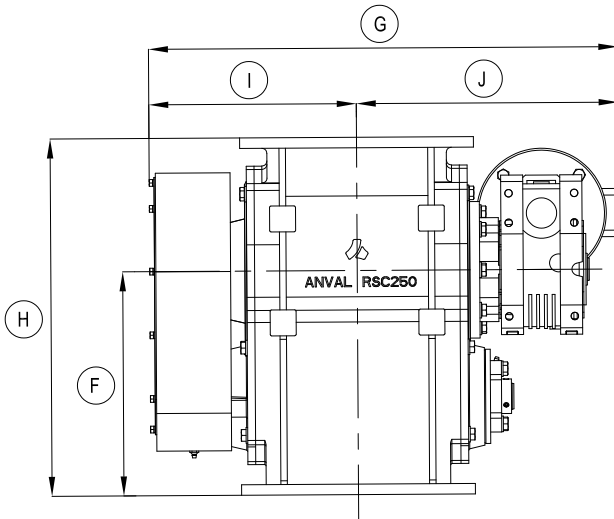

All dimensions in mm

varies with motor size and gear box variation.

NOTE: MAINTAIN OIL LEVEL IN CHAIN GUARD SUCH THAT 2 SMALL SPROCKETS ARE DIPPED IN OIL. USE LUBRICATION OIL 320GRADE.

Table 3: Dimension Details for Inline Drive (E)

Name	RSC150	RSC200	RSC 250	RSC300	RSC350	RSC 400
A	□ 150	□ 200	□ 250	□ 300	□ 350	□ 400
B	□ 240	□ 300	□ 360	□ 430	□ 480	□ 530
C#	430 OA	510 OA	543 OA	580 OA	670 OA	770 OA
D	12	12	12	16	16	20
E	Ø 15	Ø 15	Ø 15	Ø 15	Ø 15	Ø 15
F	245	295	345	395	465	550
G	560 OA	630 OA	723 OA	780 OA	895 OA	1047 OA
H	330 OA	440 OA	550 OA	660 OA	770 OA	890 OA
I	220	270	320	370	396	426
J#	360	390	403	470	525	621
Net Weight	110	160	250	280	355	450
Gross weight	135	190	310	320	410	550

All dimensions in mm. Net weight in Kgs.

Approximate dimension only.

Direct Drive (D) Component Information

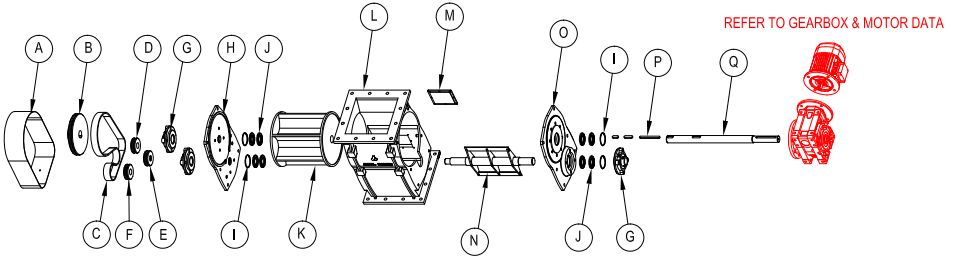
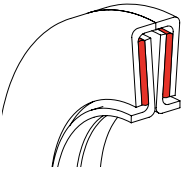

Table 5: Direct Drive (D) Component Information

Name	Description	RSC 250	RSC 400
		Quantity	Quantity
A	CHAIN GUARD	104-3476	104-5964
B	DRIVE DUPLEX SPROCKET	1	1
		104-3460	104-5954
C	DRIVE DUPLEX CHAIN	1	1
		104-3483	104-3483
D	IDLER DUPLEX SPROCKET LEFT	1	1
		104-3470	104-5958
E	DRIVEN DUPLEX SPROCKET WITH POWER LOCK	1	1
		104-3461	104-5946
F	IDLER DUPLEX SPROCKET RIGHT	1	1
		104-3474	104-5957
G	BEARING & HOUSING ASSEMBLY	100-6922	100-4140
		3	1
H	BEARING SIDE PLATE	104-3433	104-5949
		1	1
I	INTERNAL CIRCLIP	101-1786	100-6310
		4	1
J	LABYRINTH SEAL	100-6828	100-6288
		8	8
K	ROTOR	104-3431	104-5929
		1	1
L	BODY	104-3449	104-5923
		1	1
M	INSPECTION DOOR	104-3481	104-5966
		1	1
N	SECONDARY ROTOR	104-3454	104-5941
		1	1
O	DRIVE SIDE PLATE	104-3434	104-5932
		1	1
P	KEY	104-3478; 104-3479; 100-2252	101-3200; 101-0391; 100-6313
		1	1
Q	SHAFT	104-3477	104-5929
		1	1

* Optional Component.

Anval Standard



Labyrinth Seal

The Labyrinth seal, which is a mechanical seal that fits around the axle or shaft to prevent the leakage of any particles.

Generally, a Labyrinth seal is composed of many threads or grooves that are tightly fit inside the casing, thus making difficult for the dust to pass through a long and difficult path.

Labyrinth seals on rotating shafts provide a non-contact sealing action by controlling the passage of particles through a variety of chambers by centrifugal motion, as well as by the formation of controlled material vortices.

'Double labyrinth Seals' fitted with flock pads, greased on each side of the valve, are standard with all rotary valves.

- Longer life span
- Sealing not on the shaft
- No adjustments

Purge Sealing

Grease Purge (G) Sealing

For extreme duty, RSC valves are fitted with a grease purge unit over the labyrinth seal. By creating a grease filled cavity between the seals, it prevents the escape of any dust particles or gases.

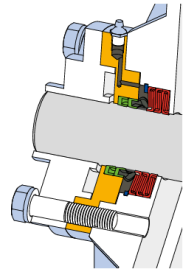

Grease Purge Sealing

Testing & Using the Valve

The equipment has been factory tested by the manufacturer. Please contact us for further information regarding ANVAL's testing processes.

Before starting the equipment, check that

- The machine incorporating the equipment complies with the provisions of the "Machinery Directive" 2006/42/EC & any other applicable safety legislation.
- The equipment's mounting position in the installation corresponds to that prescribed & indicated in installation drawing.
- The electrical power supply & control systems are suitable & operational as stipulated in standard EN 60204-1 & grounded as per standard EN 50014.
- The motor power supply corresponds to that prescribed & is within +/-5% of the rated valve.
- The motor is examined for the direction of rotation & if it runs the other way, it is to be recalibrated by a trained person
- The oil level in the gear unit is as prescribed & that there are no leaks from the caps or gaskets



Before putting the equipment into service, the user must ensure that the plant in which it is installed complies with all applicable directives, especially those regarding health & safety in the work place.



Cover the opening with a safety closure while testing the valve as per safety standard. Also ensure that the valve is never left unattended during the course of testing

Maintenance



Maintenance & replacement work must be carried out by expert maintenance technicians trained in the observance of applicable laws on health & safety at work & the special ambient problems attendant on the installation.



Before doing any work on the unit, the operator must first switch off the power to the equipment & ensure that it is out of service, as well as taking all necessary precautions against it being accidentally switch on again or its parts moving without warning.

Furthermore all additional environmental safety precautions must be taken into account (e.g. elimination of residual gas or dust, etc)

- Before doing any maintenance work, activate all safety equipment and, if necessary, inform persons working in the vicinity. In particular, mark off the area around the unit & prevent access to any equipment which, if activated, might be the cause of unexpected health & safety hazards.
- Replace worn components with original spare parts only.
- Use the lubricants recommended by the manufacturer
- When working on the gear unit always replace gaskets & seals with new original ones
- If a gear unit bearing requires replacement, it is a good practice to also replace the other bearing supporting the same shaft.
- We recommend replacing the lubricating oil after all maintenance work.

The above instructions are aimed at ensuring efficient & safe operation of the gear unit.

The manufacturer declines all liability for injury & damage to components due the use of non-original spare-parts & non-routine work which modifies the safety requirements without prior authorisation of the manufacturer.



Do not dump polluting liquids, worn parts & maintenance waste into the environment. Dispose of all such materials as stipulated by applicable legislation.

Routine Maintenance



Before working on the valve, Isolate and Disconnect the electrical supply.

The following must be checked and adjusted as necessary;

Shaft Seals

- Check and replace the shaft seals annually.

Drive Sprockets and Chain

- Check and adjust the chain drive tension quarterly.
- Before replacing the chain, examine the sprocket teeth for signs of wear and renew if necessary.
- When replacing the sprockets and drive chain ensure the sprockets are correctly aligned and the chain tension is correct.

Bearings

Standard bearing used across the RSC250 valves are greased packed, sealed for life and maintenance free. Even though they should be checked every 3 months and grease needs to be purged weekly.

When replacing the bearings, use manufacturer recommended replacement parts only. Other bearings may fit, but will not function properly. If the bearings are removed from the airlock for any reason, they must be replaced, not reinstalled.

Geared Motors

Maintain the geared motors as described in manufacturer's instructions.

Grease Purge

Greasing needs be done every month.

Gas Purge

Inert gas to be used for cleaning the product blocked in the labyrinth seals and need to be purged every month.



It is recommended that the complete rotary valve be dismantled for cleaning, inspection and overhaul as necessary at regular intervals. The intervals between such routine overhauls will vary with the product being handled and the operating time. To a larger degree the rate of wear for a particular application would be assessed by practical experience.

Lubrication

Gearbox Lubrication

Maintain or change oil as per the Gear box instruction manual.



If a leak is found, identify the cause of the fault, repair it & refill with lubricant before operating the equipment

Most Commonly used Gearbox Oil

Shell Tivela S320 or Shell (Tivela Oil SC320), Kluber (Klubersynth GH 6 320), Aral (Degol GS 320), Total (Carter SY 320), Caltex EP320, IP (Telium Oil VSF 320 oAgip) & Mobil (Glygoyle HE 320 or equivalent long-life synthetic lubricant.

- Maintain required level and change if oil is contaminated.

Bearing Lubrication

- Normal Temperature : Multipurpose grease (Monthly)

Grease Purge Lubrication (G)

- Normal Temperature : Multipurpose grease (Monthly)

Checking Efficiency

- Remove dust deposits on the surface of the equipment & its parts
- Check that noise at constant load does not vary. Excessive vibration or noise can indicate wear of the gear train or failure of a bearing
- Check the power absorption, voltage against the nominal values & any lubricant leaks
- Check all bolted couplings for wear, deformation or corrosion & tighten them down fully without over tightening
- Check the clearance for wear against the original with a feeler gauge

Maintenance Schedule

Maintenance routine statements are prescribed in the table format for easy care.

SL. NO.	DESCRIPTION	WEEKLY	MONTHLY	QUARTERLY	HALF YEARLY	ANNUALLY
1	Shaft Seals					R
2	Greasing on Bearings	L				
3	Grease Packing on Bearings			R		
4	Grease Purging		L			
5	Drive & Driven Sprockets			C & L		
6	Dust deposits on Gear Box & Motor		C			
7	Tightening of Fasteners		I			
8	Gearbox Oil Change	As per Manufacturer's Instruction. Recommended 3 months once				

NOTE: MAINTAIN OIL LEVEL IN CHAIN GUARD SUCH THAT 2 SMALL SPROCKETS ARE DIPPED IN OIL. USE LUBRICATION OIL 320GRADE.

* Based on application & Material used.

ABBREVIATION	DESCRIPTION
I	Inspect & Correct or Replace if necessary
R	Replace or Change
L	Lubricate
C	Clean
A	Adjust

Surface Cleaning

Clean all dust & process waste off the equipment. Do not use solvents or other products which are incompatible with the construction material and do not direct high-pressure jets of water at the gear unit.



If the equipment is to be painted, tape the nameplate & seal rings to prevent contact with solvent.

Replacing & Scrapping

Replacing Parts

- Do not hesitate to replace parts and/or components if they are not able to guarantee safe and reliable operation.
- Never improvise repairs
- The use of non-original spare parts not only voids the warranty but can compromise gear unit operation.

Scrapping the Equipment

- This must only be done by operators trained in the observance of applicable laws on health & safety in the workplace.
- Do not dump non-biodegradable products, lubricants & non-ferrous materials (rubber, PVC, resins, etc.) into the environment.
- Dispose of all such materials as stipulated by applicable environmental protection legislation.



Do not attempt to re-use parts or components which appear to be in good condition after they have been checked and/or replaced by qualified personnel and declared unsuitable for use.

Troubleshooting

Below table provides information on common problems, causes & solutions of the equipment

Problem	Cause	Solution
Motor Stalls	Foreign or large object jammed between rotor & body	Objects needs to be removed. Reverse the motor for few seconds so that object may re-arrange itself & fall through
	Product size too large , lumpy or stringy with valve running at 100% full	Increase the valve speed so that rotor pockets are only partially full allowing larger objects to pass
	Electric overload set too low	Reset
Air Leaks Past Rotor	Excessive pressure downstream due to blockage or design fault	Check & make necessary changes
	Rotor damaged	Check & replace if necessary
Excessive Equipment Noise	Rotor moved to side or foreign body caught in rotor	Re-adjust rotor or remove foreign body
Seal Leakage	Seal damaged	Replace seal
	Pressure too high for standard seal	Fit grease purge seal
	Circlip not in place, allowing seal to move	Check Circlip and refit if necessary
Minimal or No Product Discharge	Rotor clogged up due to sticky material	Check through inspection opening & clean if necessary
	Failure of part of the drive train	check out & replace faulty component
Abnormal Noise at Gear unit Mounting	Mounting bolts loose	Tighten down to specified torque
	Mounting bolts worn	Replace bolts
Gear unit Oil Leaks	Oil level too high	Check oil level and make necessary changes
	Casing/Coupling seals inadequate	Contact authorised workshop
	Gaskets worn	Contact authorised workshop
Gear unit doesn't run or runs with difficulty	Oil Viscosity too high	Replace oil
	Oil level too high	Check oil level for required changes
	Service load too high	Redesign drive for actual service load
Output shaft doesn't turn with motor running	Gears damaged	Contact authorised workshop

Notes

Notes

Notes

Disclaimer:

All drawings are conceptual only and are subject to change without notice at the discretion; Anval Valves reserves the right to make additions, deletions and modifications to the drawings. Individual product dimensions indicated are approximate, may vary due to construction, and may vary from individual requirements indicated here within and may vary with actual construction.

E: infoanval.net
W: www.anval.net



CLIENT

CLIENT ADDRESS

PROJECT

PO No & MODEL No



Try our Innovative Product Configurator at <https://configurator.anval.net/>