

BH SERIES

HIGH EFFICIENCY BLOW THROUGH VALVE

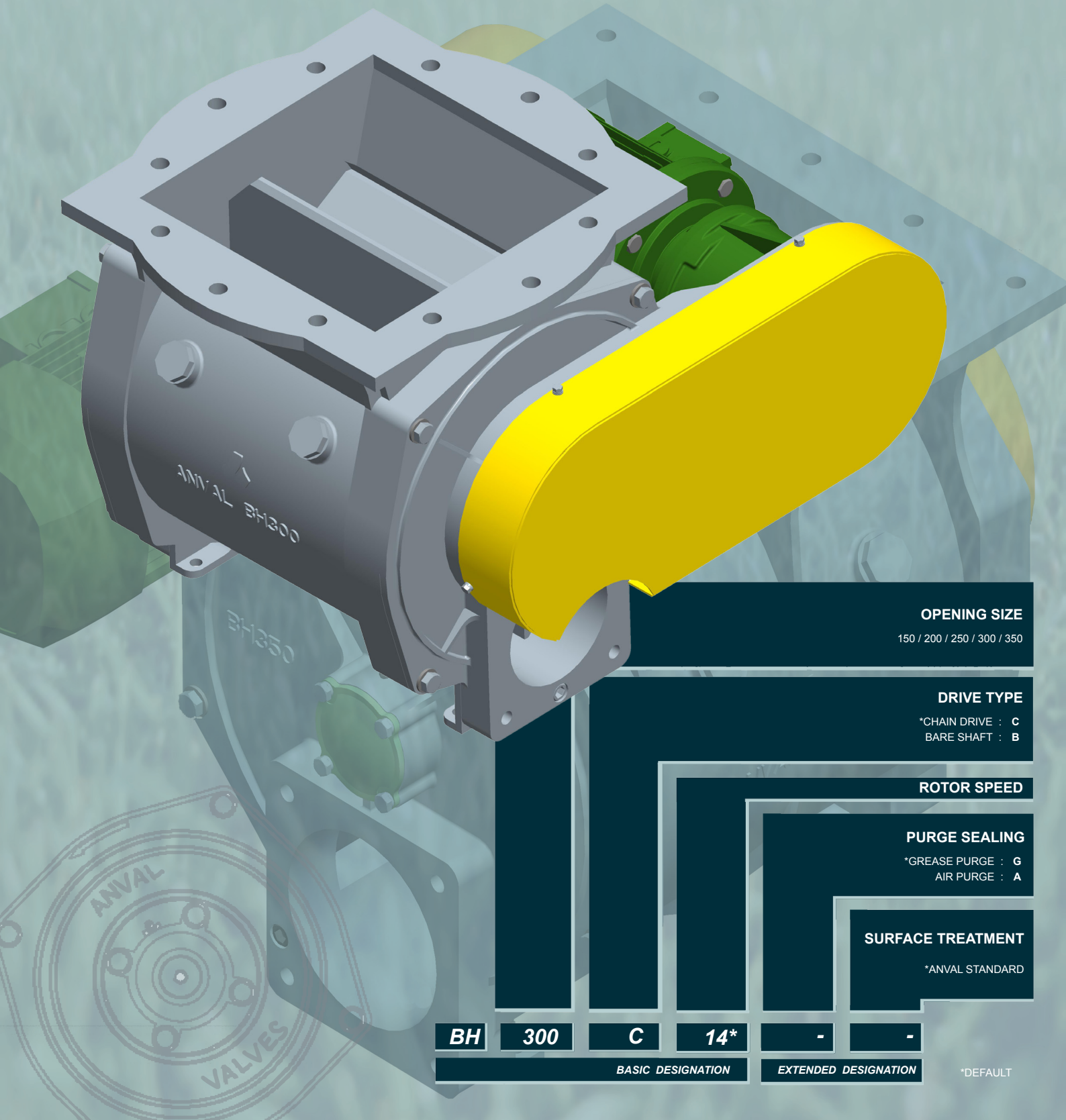

OPENING SIZE

150 / 200 / 250 / 300 / 350

DRIVE TYPE

*CHAIN DRIVE : C
BARE SHAFT : B

ROTOR SPEED

PURGE SEALING

*GREASE PURGE : G
AIR PURGE : A

SURFACE TREATMENT

*ANVAL STANDARD

BH	300	C	14*	-	-
BASIC DESIGNATION			EXTENDED DESIGNATION		

*DEFAULT

CHAIN DRIVE (C) > BH150 > BH200 > BH250 > BH300 > DIMENSIONS

BH

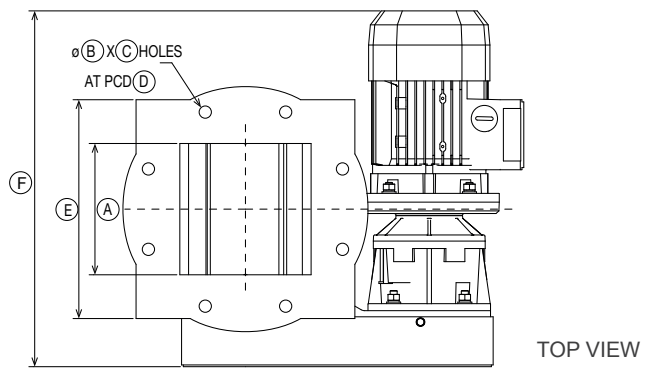

NAME	BH 150	BH 200	BH 250	BH 300
A	150 x 150	202 x 202	255 x 255	300 x 300
B	14	14	22	17.5
C	8	8	8	12
D	240	295	350	400
E	250 x 250	305 x 305	360 x 360	400 x 400
F#	407	442	473	473
G#	458	528	607	673
H	245	320	405	470
I	120	165	205	235
J	77	96	120	140
K	90 x 90	110 x 110	150 x 150	180 x 180
L	53	63	103	125
M	M12	M16	M16	M16
N	4	4	4	4
P	90	115	165	195
Q	350	420	508	558
NET WEIGHT	39	65	115	150
GROSS WEIGHT	48	78	128	169

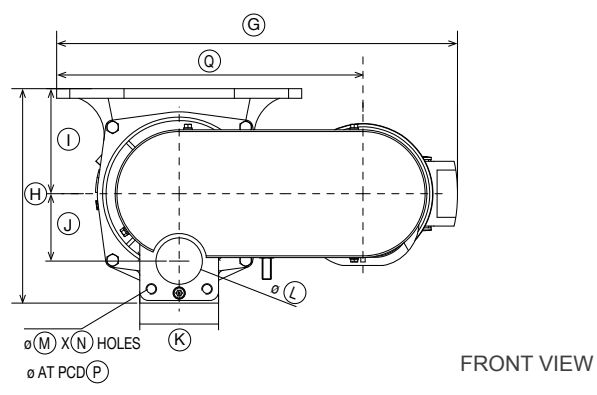

ALL DIMENSIONS IN MM, WEIGHT IN KGS.

#APPROXIMATE DIMENSION ONLY. VARIES WITH MOTOR SIZE AND GEARBOX VARIATION.

CHAIN DRIVE (C) > BH350 > DIMENSIONS

BH

NAME	BH 350
A	350 X 350
B	15
C	16
D	106
E	□ 480
F#	596
G#	748
H	530
I	265
J	160
K	200 X 200
L	154
M	M16
N	4
P	220
Q	615
NET WEIGHT	216
GROSS WEIGHT	236

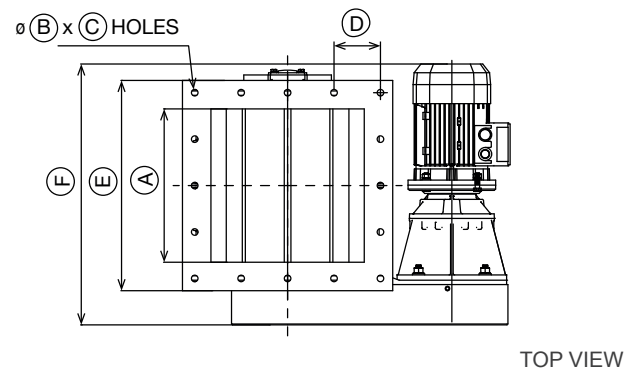

ALL DIMENSIONS IN MM, WEIGHT IN KGS.

#APPROXIMATE DIMENSION ONLY. VARIES WITH MOTOR SIZE AND GEARBOX VARIATION.

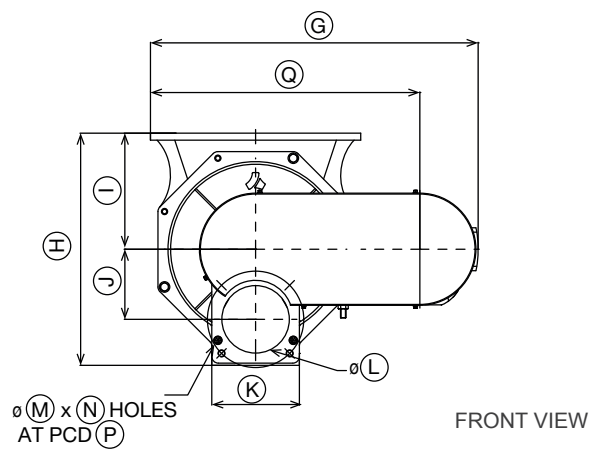

BARE SHAFT (B) > DIMENSIONS

BH

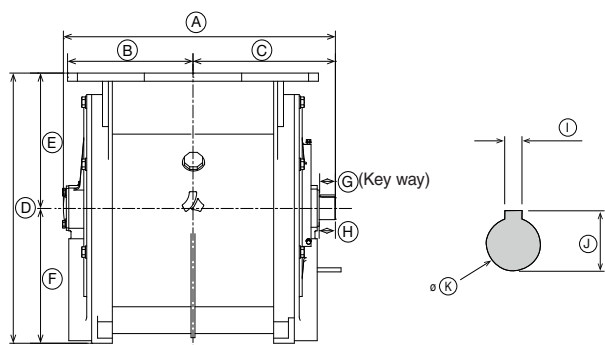

FRONT VIEW

NAME	BH 150	BH 200	BH 250	BH 300	BH 350
A	300	351	431	498	553
B	140	170	197.5	227.5	235
C	160	181	233.5	270.5	318
D	245	320	405	470	530
E	120	165	205	235	265
F	125	155	200	235	265
G	25	26	25	25	32
H	26	26	26	32.3	33
I	8	8	12	12	14
J	28	33	43	43	48.5
K	25	30	40	40	45
NET WEIGHT	30	49	90	116	172
GROSS WEIGHT	48	78	128	169	236

ALL DIMENSIONS IN MM, WEIGHT IN KGS.

ROTORS

The standard BH Series rotor is fabricated open-end style, the most common rotor assembly design. Open rotors refers to the open pocket at each end of the rotor .

Default design comes with 6 vanes.

Rotor is perfectly designed and manufactured to have a close radial clearance tolerance of 0.10 mm (Max.)

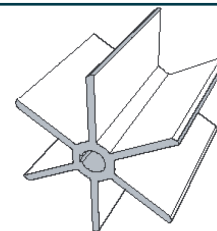

OPEN ROTOR

BH

SHAFT SEALING

BH

We are using labyrinth seal, which is a mechanical seal that fits around the axle or shaft to prevent the leakage of any particles. Generally, Labyrinth seal is composed of many threads or grooves that are tightly fit inside the casing, thus making difficult for the dust to pass through a long and difficult path.

Labyrinth seals on rotating shafts provide non contact sealing action by controlling the passage of particles through a variety of chambers by centrifugal motion, as well as by the formation of controlled material vortices.

'Double labyrinth Seals' are filled with flock pads, and greased on each side of the valve. These are standard with all BH Series valves.

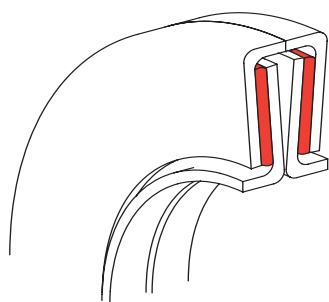

LABYRINTH SEAL

Grease Purge - Standard Valves is fitted with a grease purge unit over the labyrinth seal. By creating a grease filled cavity between the seals, it prevents the escape of any dust particles or gases.

Air Purge - When grease cannot be used, air or other gases can be used to purge the seal so all dust particles or product gases are flushed back into the product stream.

BH VALVE BODY

BH

The standard BH Series body is fully cast on a single piece reducing the number of seams for wear. In addition, as all of the components are manufactured from cast iron, the valve has all of the advantages of cast iron over traditional mild steel including superior corrosion resistance, better wear properties and thermal stability.

BEST FIT FOR

- Pneumatic conveying systems to achieve smoother flow of materials.
- Food, Flour, Grains, Plastic, Chemical, Pharma & milling industries.

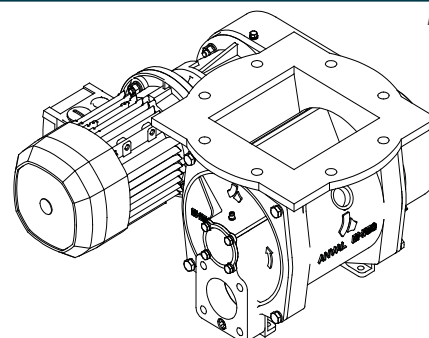

ATEX VERSION IS ALSO AVAILABLE.

MODEL SELECTION CHART

Speed Vs Throughput

Capacity Chart

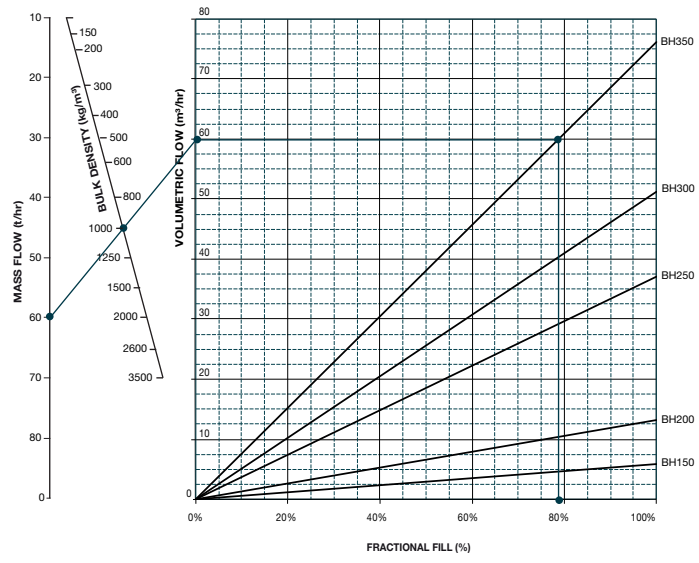
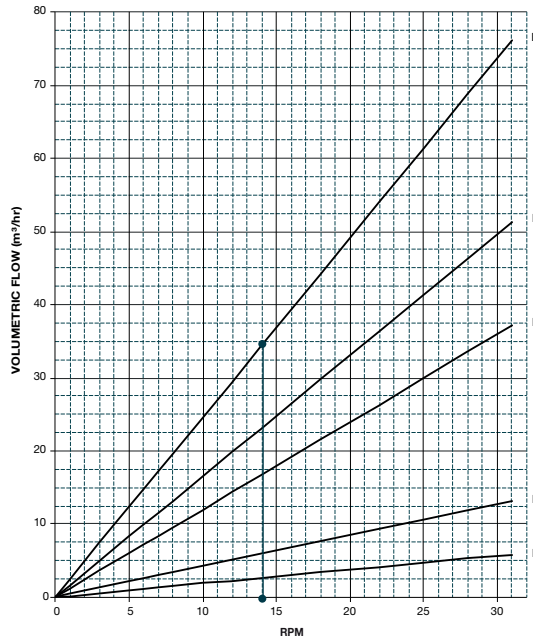

• 14 RPM DEFAULT FOR BH 150 / 200 / 250 / 300 / 350

NOTE: THIS CHART IS PREPARED FOR THE GUIDANCE PURPOSE ONLY, CONSIDERING 100% FILLING CAPACITY.

EXAMPLE: A MATERIAL WITH A BULK DENSITY OF 1000 (Kg/m³) AND REQUIRED CAPACITY OF 60 (t/hr) CAN BE ACHIEVED BY BH 350 AT 78% FILLING CAPACITY WITH 31 RPM.

NOTE: THIS CHART IS PREPARED FOR THE GUIDANCE PURPOSE ONLY, CONSIDERING MAX. RPM

CONSTRUCTION / TECHNICAL SPECIFICATIONS

<p>BODY : Cast Iron</p> <p>ROTOR : MS Fabricated - Open Rotor type</p> <p>SIDE PLATES : Cast Iron</p> <p>GEARBOX : Helical Gears</p> <p>SEALS : Labyrinth Seals (sealing washer)</p> <p>DRIVE TYPE : Chain / Bare Shaft</p> <p>PAINTING STANDARD : Dark Grey Blue</p> <p>SPECIAL SEALS : Grease Purge / Air Purge</p>	<p>BEARINGS : In board</p> <p>SHAFT : CS1030</p> <p>OPENING SIZES : 150, 200, 250, 300, 350 mm</p> <p>TEMPERATURE : Built to eminent temperature</p> <p>DIFFERENTIAL PRESSURE : Can handle higher pressure</p> <p>CAPACITY RANGE : upto 76 m³/hr Max.</p> <p>SURFACE TREATMENT (ANVAL STANDARD) : 50µm Grey Primer 50µm Paracryl IFC (B53 Dk. Grey Blue / Y14 Golden Yellow for guards.)</p>
-------------------------------------------------------------------------------------------------------------------------------------------------------------------------------------------------------------------------------------------------------------------------------------------------------------------------------------------------------------------------------	---------------------------------------------------------------------------------------------------------------------------------------------------------------------------------------------------------------------------------------------------------------------------------------------------------------------------------------------------------------------------------------------------------------------------------------------------

NOTE: SPECIAL CONSTRUCTIONS ARE AVAILABLE FOR HIGHER DIFFERENTIAL PRESSURE AND TEMPERATURE.



OUR LOCATIONS

Rev : May 2016 - 3

<p>AUSTRALIA</p> <p>+61 8 9726 0988</p>	<p>INDIA</p> <p>+91 74492 00 505 / 432</p>	<p>UNITED KINGDOM</p> <p>+44 (0) 207 117 2067</p>	<p>SINGAPORE</p> <p>+61 8 9726 0988</p>
------------------------------------------------	---------------------------------------------------	----------------------------------------------------------	------------------------------------------------

www.anval.net | info@anval.net